

# HELISTAR

## ERB-□□ 電磁負動作彈簧制動器(安全煞車)

### Spring-applied brake

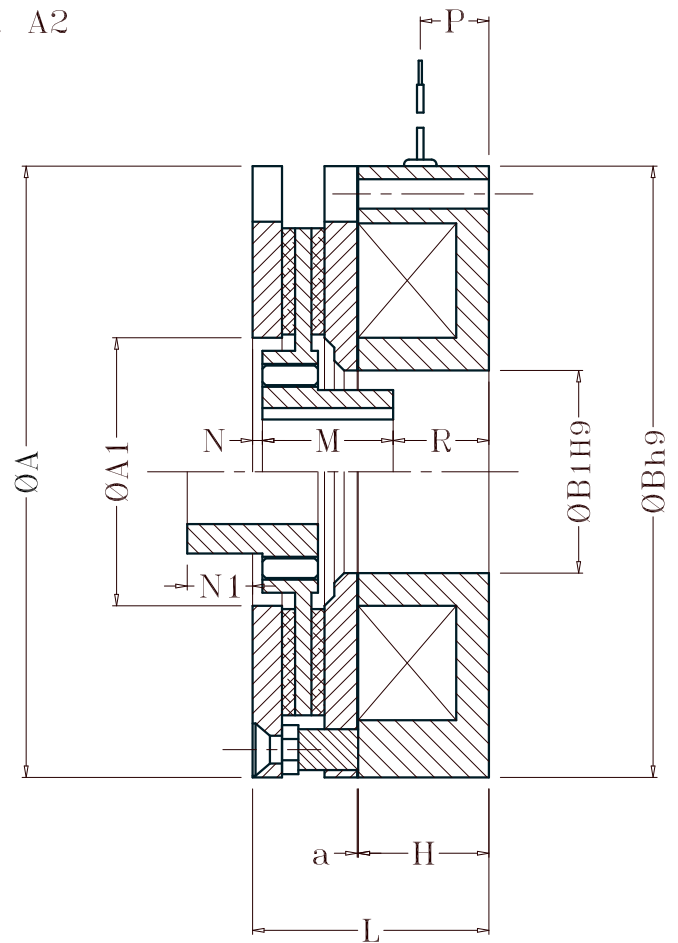
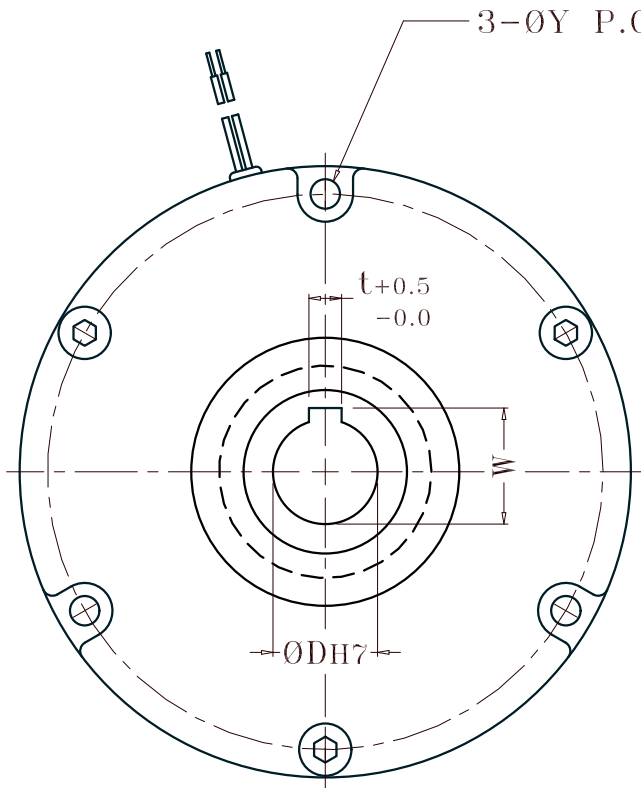

型號Model	0.1	0.2	0.6	1.5	2.5	5	10	20/30	
徑向尺寸 (Diameter)	A	63	63	97	120	150	165	187	272
	A1	25	25	46.5	47	56	72	82	102
	A2	54	54	85	108	130	147.5	170	256   221
	B	63	63	97	120	150	165	187	240
	B1	22	22	31	37	56	62	62	80
	H	17.8	20.8	27	30	38	33	40	59
	Y	4.5	4.5	5.5	5.5	7	9	9	9   11
軸向尺寸 (Length)	L	28.5	31.5	44.9	48	60.3	61.3	72.3	98.5
	M	13	13	18	25	25	30	40	50
	N	2.5	2.5	4.7	4	3	7.3	3	4
	N1	5.5	5.5	4.5	11	*	9.7	20	26
	P	6.8	6.8	8	16	17.5	16	21	25
	R	13	13	22.5	19.2	32.3	24	29.3	45
	a	0.2 ±0.05	0.2 ±0.05	0.2 ±0.05	0.2 ±0.05	0.2 ±0.05	0.25 ±0.05	0.3 ±0.05	0.3 ±0.1
鍵 (Key)	D	10	10	14	19	20   24	28	32	32   45
	W	*	*	16.2	21.1	22.3   26.3	31	35.5	35.5   48.5
	t	*	*	5	5	5   5	7	10	10   12
質量 weight	0.6	0.6	1.2	3.4	5.5	7.9	12.5	26	